

**ITW Angleboard**

# Formaboard™



## The perfect edge to protect your product line

- High-Strength Performance
- Ideal in All Climates
- Reduces Packaging Costs
- Excellent for Product I.D.



**100% Recyclable**

ITW Angleboard products are made from recycled materials and are 100% recyclable.

**ITW Angleboard**

We've got all the angles covered.

# Formaboard

100% Recyclable

ITW AngleWrap products are made from recycled materials and are 100% recyclable.

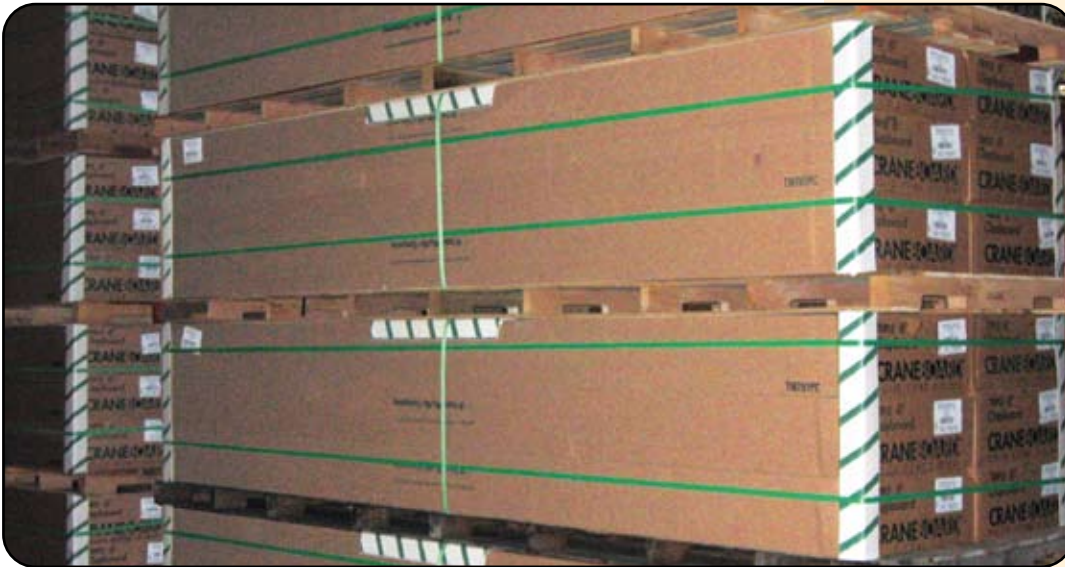

## Fit for Outdoors • Exceptional Strength

**Formaboard™** utilizes a unique, patented manufacturing process to heat bond polycoated plies of paper, forming them into rigid right angles of exceptional strength. Formaboard's superior strength properties enable customers to use a thinner caliper and/or shorter leg length than with a standard open-edge product without sacrificing performance.

Formaboard:

- Is water and moisture resistant
- Is ideal for products that are exposed to the elements, such as humidity
- Is made of lightweight material
- Works well with refrigerated/frozen food where condensation is an issue
- Has a higher strength that can lower costs through reduction in caliper
- Can be printed on for product identification

One and two-color printing is also available for branding, product identification and instructional purposes.

### ITW Angleboard

595 Telser Road • Suite 100 • Lake Zurich, Illinois 60047  
Phone: 1-800-252-4777 • [www.angleboard.com](http://www.angleboard.com)

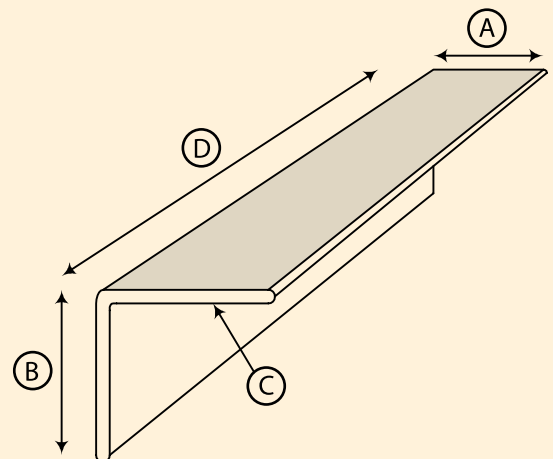
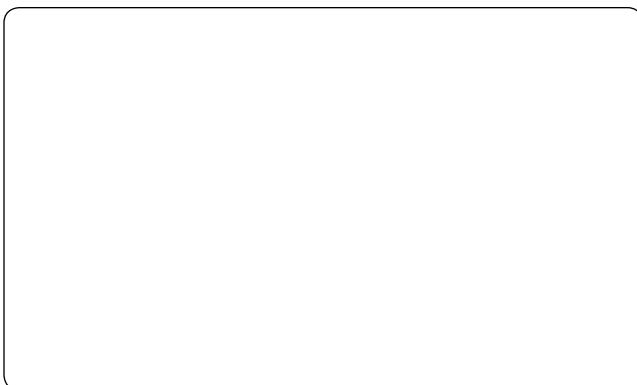

## Specifications

Formaboard sizes are based on the following dimensions\*:

- A Leg Length One – Available from 1.375 – 3 inches (34.9 mm – 76.2 mm)**
- B Leg Length Two – Available from 1.375 – 3 inches (34.9 mm – 76.2 mm)**
- C Caliper – Available from .040 – .280 inches (1.0 mm – 7.1 mm)**
- D Length – Available from 2.5 inches – 144 inches (63.5 mm – 3,657.6 mm)**

\*Together, Formaboard leg lengths cannot exceed 6 inches (152.4 mm).