

ITW Angleboard

# AngleWrap®



**The perfect edge to protect your product line**

- **Greater Strength**
- **Eliminates Delamination**
- **Prevents Paper Cuts**
- **Cleaner Appearance**



**100% Recyclable**

ITW Angleboard products are made from 100% recycled materials and are 100% recyclable.

ITW Angleboard

We've got all the angles covered.

# ITW Angleboard AngleWrap

**100% Recyclable**

ITW Angleboard products are made from 100% recycled materials and are 100% recyclable.



## Stronger • No Paper Cuts • No Delamination

**AngleWrap®** is made of multiple plies of recycled paper, laminated together with glue and encased in a full outer wrap of paper. The board is then formed into a rigid right angle.

AngleWrap:

- Reduces the packaging cost-per-load
- Increases strength
- Is safer to handle
- Provides a clean, crisp appearance for POP displays
- Is an excellent replacement for wood packaging
- Permits higher strap tension for tighter, more secure loads
- Prevents paper cuts and delamination

Special surface finishes are available, including moisture-resistant and abrasion-resistant coatings. One and two-color printing is also available for branding, product identification and instructional purposes.

### ITW Angleboard

595 Telser Road • Suite 100 • Lake Zurich, Illinois 60047  
Phone: 1-800-252-4777 • [www.angleboard.com](http://www.angleboard.com)

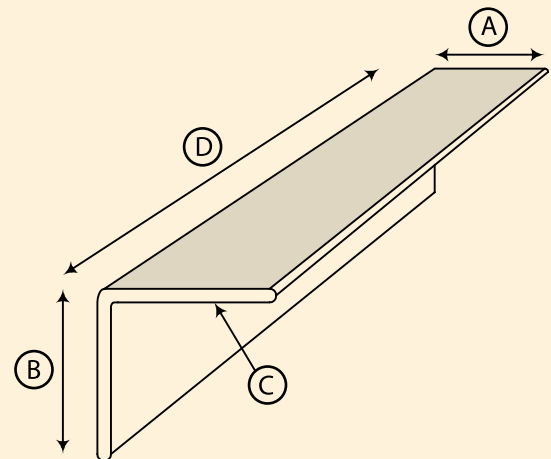

### Specifications

**Angleboard sizes are based on the following dimensions\*:**

- A Leg Length One –**  
Available from 1.5 – 2.5 inches (38.1 mm – 63.5 mm)
- B Leg Length Two –**  
Available from 1.5 – 2.5 inches (38.1 mm – 63.5 mm)
- C Caliper –**  
Available from .120 – .250 inches (3 mm – 6.4 mm)
- D Length –**  
Available from 2 inches – 240 inches (50.8 mm – 6,096 mm)

\*Together, the AngleWrap leg lengths cannot exceed 5 inches (125 mm). Combined leg lengths measuring more than 5 inches will be manufactured in Angleboard (non-wrapped) product.